

StreetHeat SR-120 OPERATIONS MANUAL

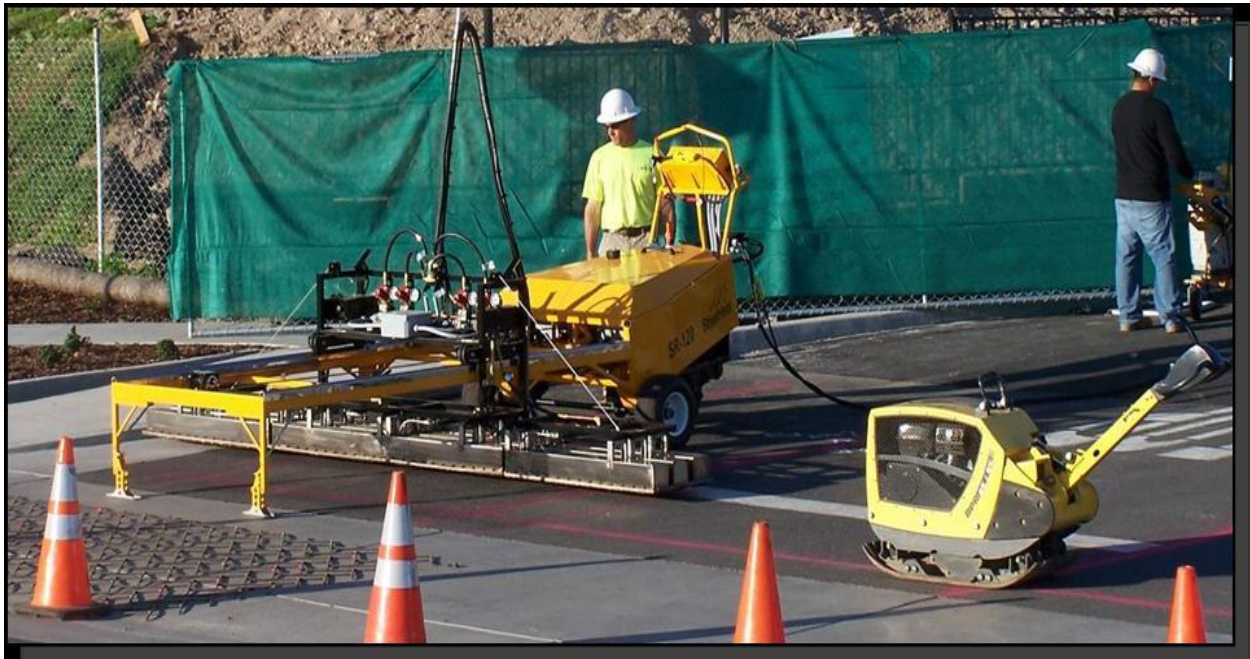

Operations Manual Contents

1. Introduction
2. Operating Principle
3. Safety
4. Power Requirements and Specs
5. Dimensions
6. Preparing for Work
7. Operating Procedure
8. Using a DuraTherm Bridge
9. Preparing for Transport



SR-120 Operating Principle

The StreetHeat SR-120 is an asphalt reheat machine specially designed for use in applying decorative StreetPrint and DuraTherm.

A bank of high intensity infrared heaters reciprocates (moves back and forth automatically) above the asphalt surface on a rail system, heating and softening an area of asphalt of up to 13 feet by 10 feet (3.95m x 3.0m).



It is important never to exceed an asphalt surface temperature of 320°F (160°C), as this will dramatically shorten the life of the decorative product. The reciprocating heater bed allows you to monitor and control the surface temperature using an infrared temperature gauge.



The asphalt needs to be heated so that it is softened to a depth of at least ½" (12.5mm). In typical summer conditions this requires heating the asphalt surface to between 225°F (110°C) and 300°F (150°C). This could take anywhere from 4 to 10 minutes depending on weather conditions and the nature of the asphalt.

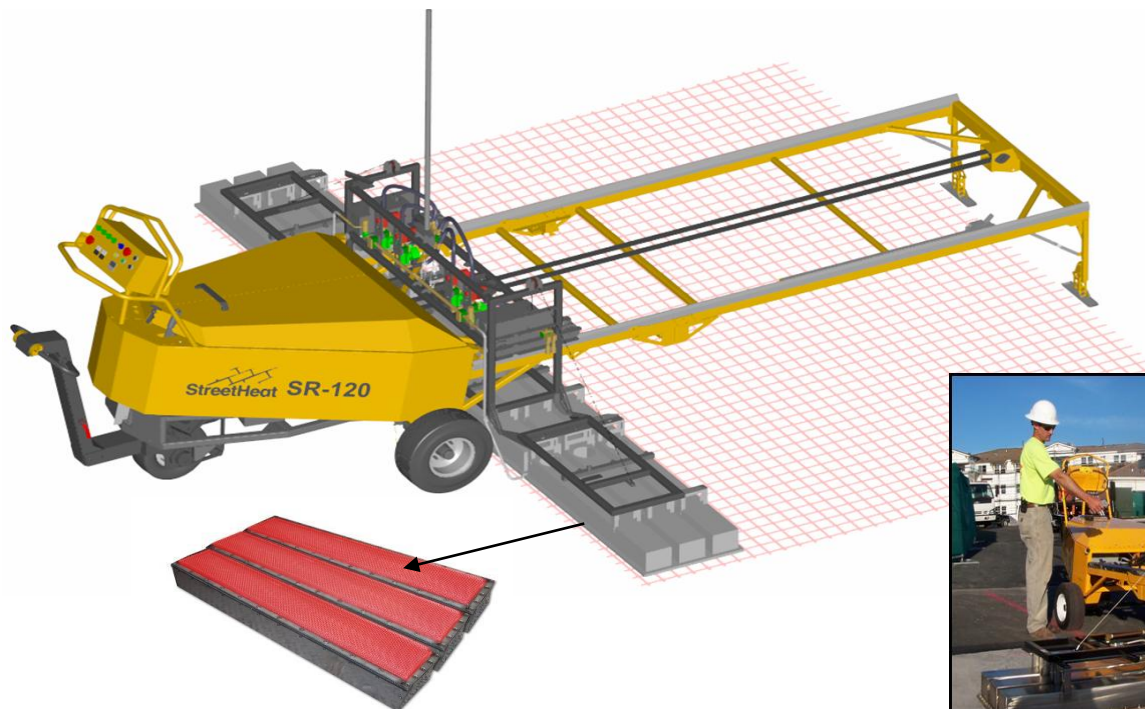

Key Safety Points

- a) **Emergency Shutoff while Driving** - Push the red Emergency Stop (E-stop) button on the bottom left of the control panel. This disconnects all battery powered operations – the drive motor and the wing-fold motors.
- b) **Emergency Shutoff during Heating** - In case of emergency, push the red E-stop button on the top right of the control panel. This shuts off power to the heater reciprocation motor and propane flow to the heaters. The pilot lights are not shut off using this button.
- c) **Emergency Hand Brake**
- d) **Heater Drive Belt** - Keep hands and loose clothing clear of reciprocation belt and pulleys.
- e) **Heating Zone** - The operator must always keep clear and ensure that others are kept clear of the heating zone, as there is a danger of being hit or burnt by the reciprocating heaters.
- f) **Electrical System** – The control box and electrical component and junction boxes must only be opened and serviced by qualified personnel, and always with the power disconnected completely. **Never bypass the Ground Fault Interrupt** (located on the front of the steering handle)! **Without it there is a risk of serious injury or death from electric shock!**
- g) **Drive Wheel Chain** – Keep hands and loose clothing clear of drive wheel chain.
- h) **Main Propane Shutoff Valve** – In any emergency, push the E-stop button then immediately close the main propane valve (h) and then the valves on the propane bottles.

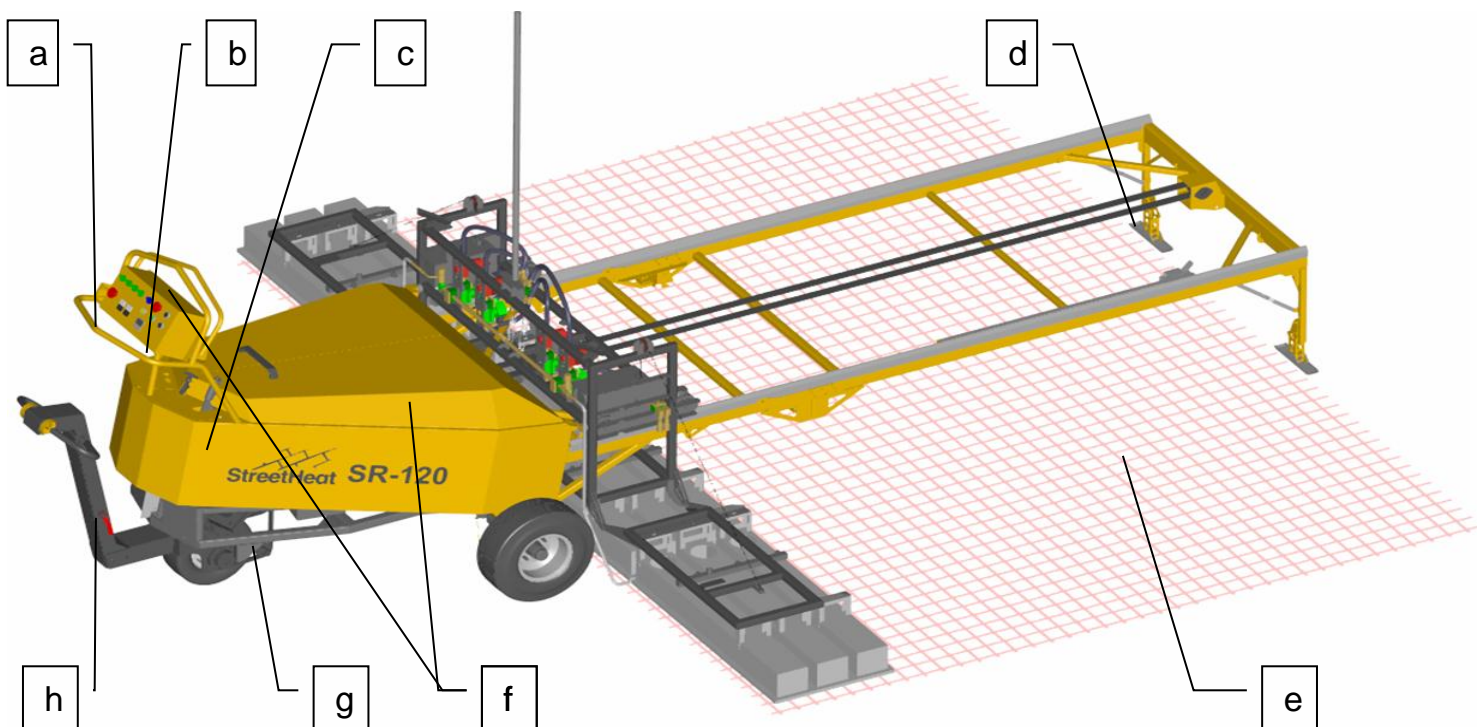

General Safety - The SR-120 is a propane-fired, self propelled, heating apparatus. Operating it carelessly or without reading the operating instructions could lead to serious injury or death. Keep everyone clear of the heaters while they ignite on the first cycle.

Smoking - Never smoke when operating this equipment or while handling the propane bottles and hoses.

Qualified Personnel

- a) Operators of the SR-120 should be experienced in operating some form of construction equipment.
- b) Operators must have read and fully understood this manual.
- c) No one under the influence of drugs or alcohol should operate this equipment.

Safety Equipment Required

- a) Safety glasses
- b) Gloves
- c) Hard toe boots
- d) Long pants
- e) Ear protection
- f) Fire extinguisher

Propane Bottles

- a) **Always** ensure that the propane bottles are safely secured to the transport trailer when mobilizing. **NEVER TRANSPORT OR STORE PROPANE BOTTLES IN AN ENCLOSED SPACE**
- b) Frequently check for leaky fittings using a small spray bottle containing a soapy water solution.
- c) Never operate machine with propane bottles placed on their side. The SR-60 requires propane vapor, not liquid.
- d) Always transport propane bottles in the upright position and with the regulator and hoses removed.

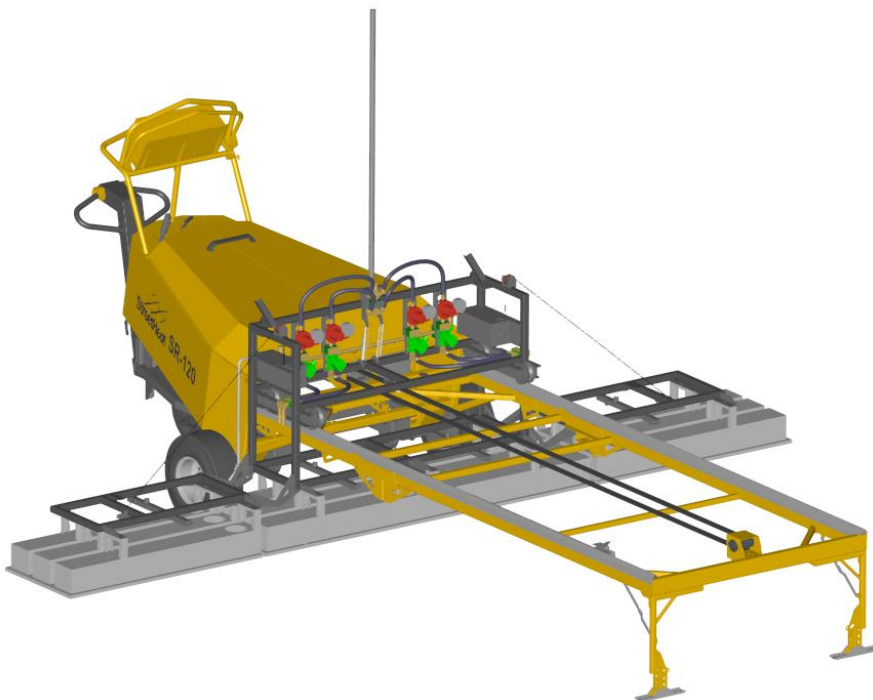

Power Requirements & Specs



Due to sensitivity of the electronics on the SR-120, it is required to use a Honda EU3000 (3000 w) generator with a built in inverter. This generator supplies the stable, clean power needed to run electrical components. It responds to the small voltage fluctuations needed by the SR-120 and is engineered not to spike voltage.

Most common generators do not have these benefits which can result in downtime of the SR-120, due to component failure, when they are used.

The Honda EU3000 (3000 w) generator with a built in inverter has been and tested and proven successful during development of the SR-120.

NOTE: Using any other generator will void the SR-120 warranty.



Electrical	Motor	Load	Power Source
Drive System	24 VDC	39 Amps	Batteries
Wing Fold	12 VDC	10 Amps	Batteries
Heater Reciprocation	90 VDC	3.36 Amps	110 VAC

Drive Speed	100 feet/min / 30 m/min
Max Drive Gradient (without assistance)	14%
Infrared Heat Source	Propane
Amount of Heat	840,000 BTU / 250 KW-hr
Machine Weight	1,850 lbs / 840 kg

Dimensions

WORKING DIMENSIONS

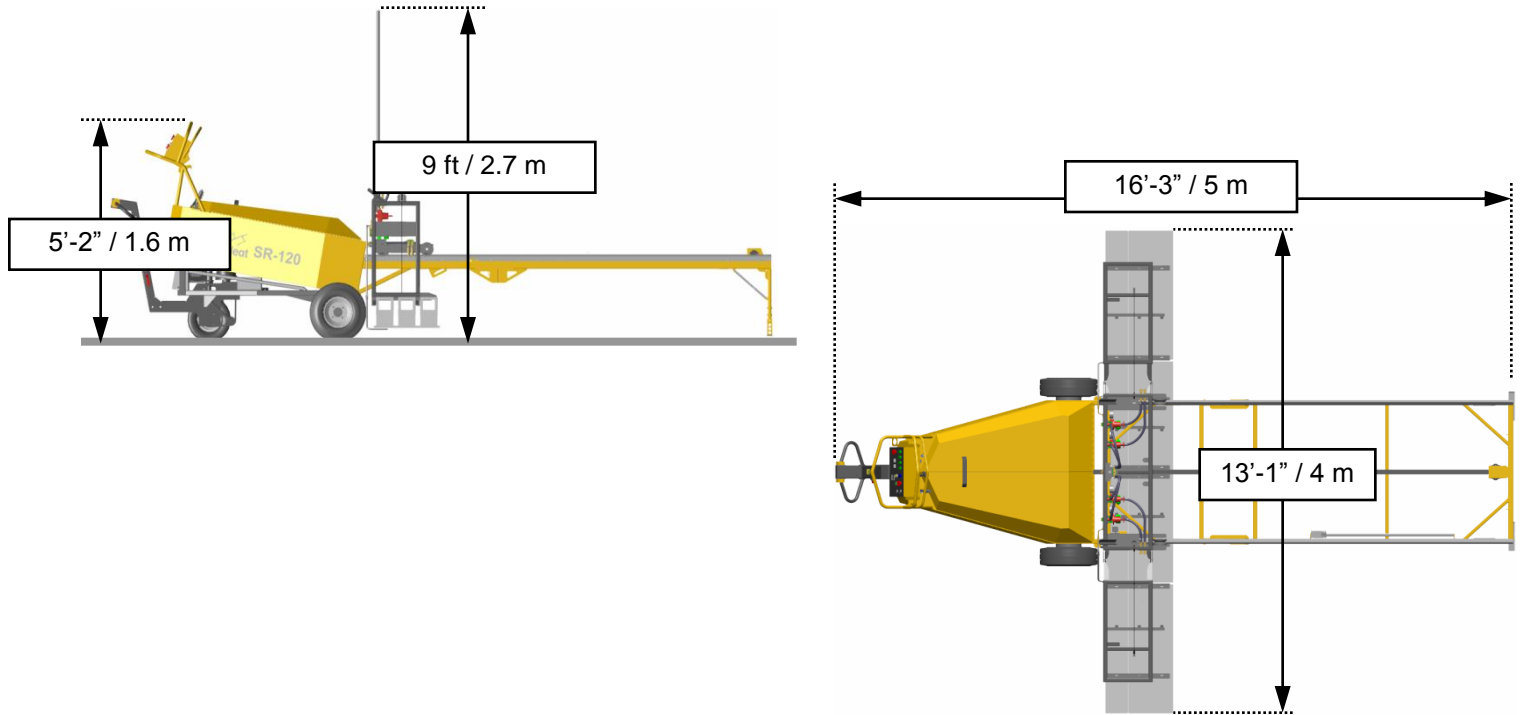

FOLDED DIMENSIONS

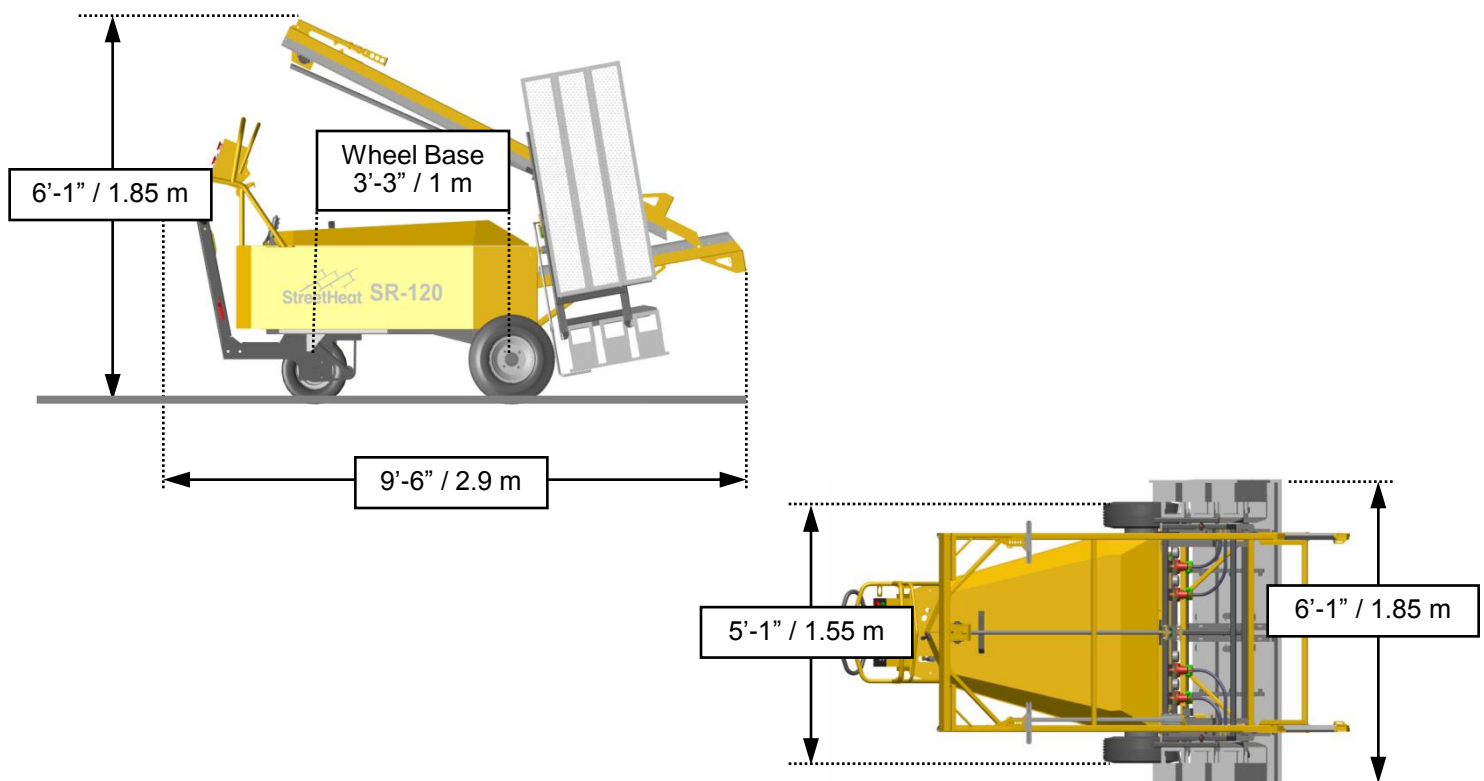

EFFECTIVE HEATING AREA

The Overall Heating Area is 13' x 10' / 3.96 m x 3.05 m = 130 sqft / 12.01 sqm.
However, the Effective Heating Area will vary depending on the nature of the job:

When Stamping:

$$12'-8" / 3.86 \text{ m} \times 9' / 2.75 \text{ m} = 114 \text{ sqft} / 10.6 \text{ sqm}$$

When Melting Thermoplastics:

$$12'-6" / 3.81 \text{ m} \times 8' / 2.44 \text{ m} = 100 \text{ sqft} / 9.3 \text{ sqm}$$

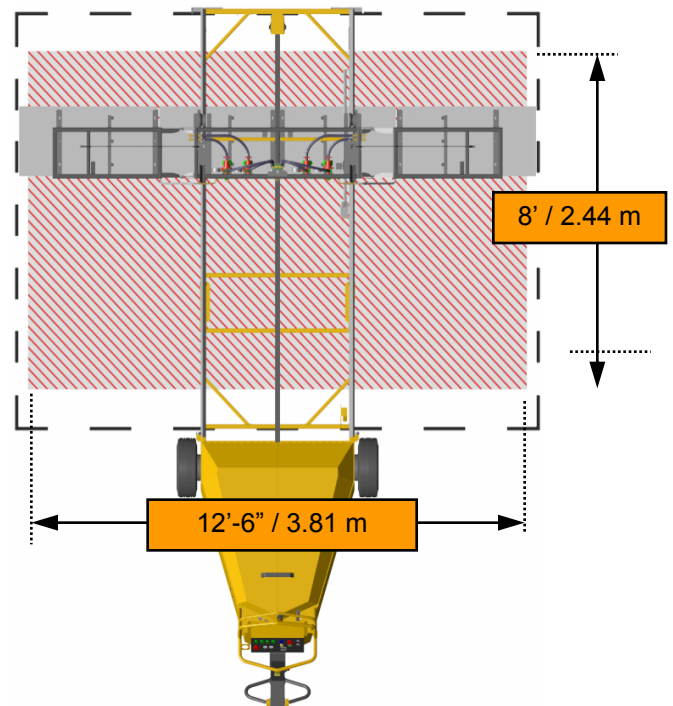
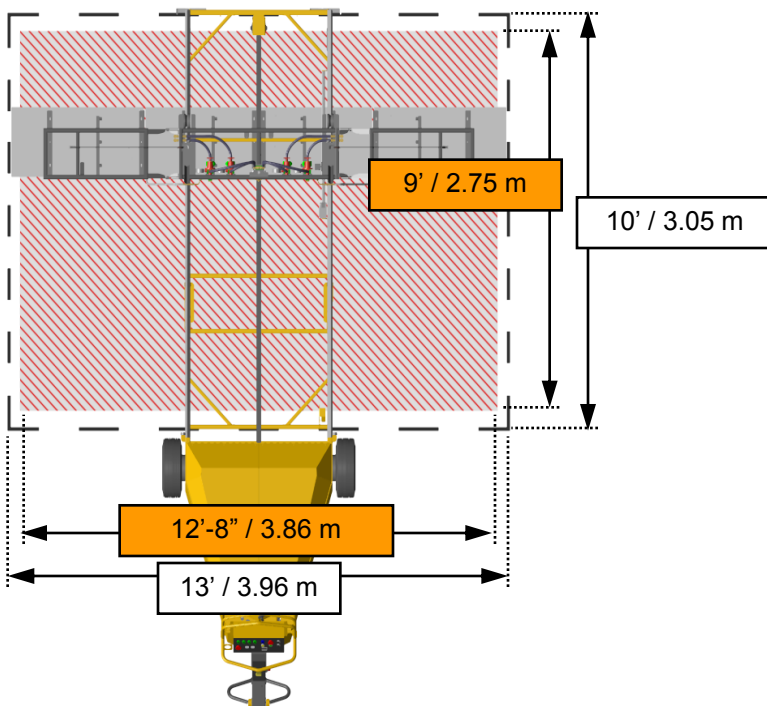

Preparing For Work



Front Legs- Extend the front legs.
CAUTION: Keep fingers clear of the point where the leg is adjacent to the rail. There is a risk of squashing fingers.



Rails – ALWAYS HAVE 2 PEOPLE PERFORM THIS OPERATION: RISK OF INJURY OR SERIOUS DAMAGE IF THE RAIL IS DROPPED. Un-strap the rail fold bar and pull rail into upright position.



Replace Rail Fold Bar before lowering. Make sure that the SAFETY STRAP is re-latched to prevent the rail fold bar falling when heating.

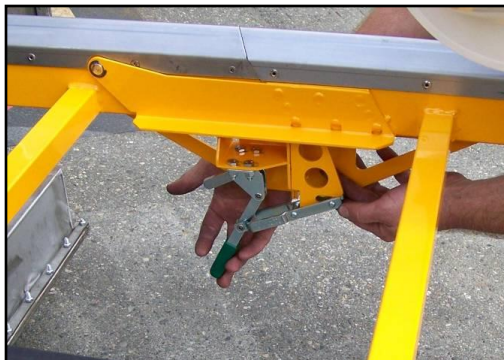

Latch the rails – lock the rails in place with the over-center latches

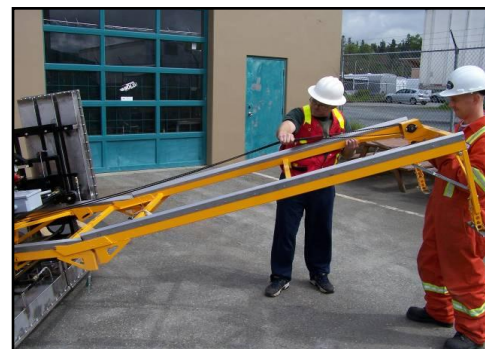

Ensure Belt Seated – Before folding down all the way make sure the long timing belt is seated properly front and back

Preparing For Work

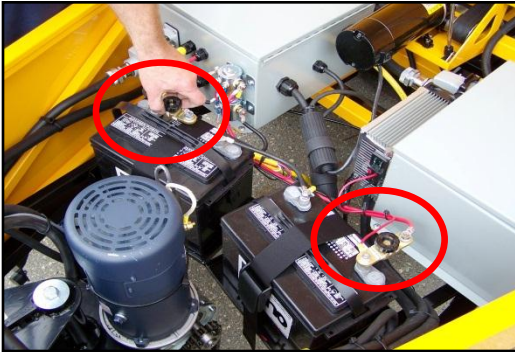

Battery Switches - These are to prevent drainage of the batteries over time. Tighten the knobs to connect to the battery; unscrew the knobs 2-3 turns to disconnect from the battery. Note: the batteries will charge with the switches disconnected (unscrewed)



Turn on the Battery Power - Pull up on the lower left emergency stop (E-stop) button. You should hear the solenoid switches “click” on.



Driving the Machine - Before driving, make sure the machine is tilted back (see next page). Using either with the left or right hand, carefully rotate the throttle paddles forwards to go forward...

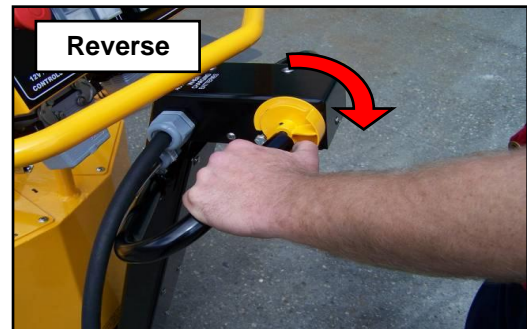

...and rotate the throttle paddles backwards to go backward. When not being driven, push the power E-stop button to prevent any accidental movement.

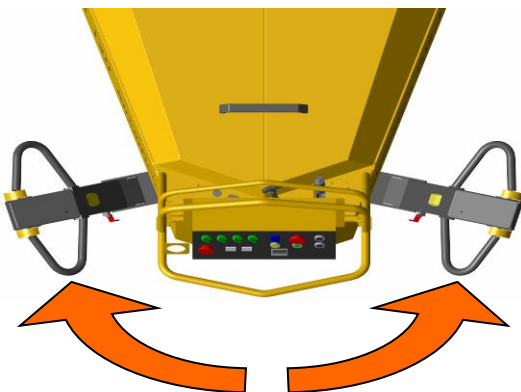

Maneuvering - The steering arm can rotate more than 160°. When first using the machine practice driving in a large open space until driving skill is developed.

RISK OF INJURY OR DAMAGE! Extreme care must be taken when driving the SR-120, especially in a tight turn because the long rail can swing around very quickly.

Preparing For Work

Wing Deployment Controls - The heater wings can be raised or lowered with battery power using these buttons. When folding them up the motor will stop automatically at the top. However, when lowering, care must be taken to stop at the desired level so the cable doesn't unravel. Use this feature to adjust the heater height as needed.

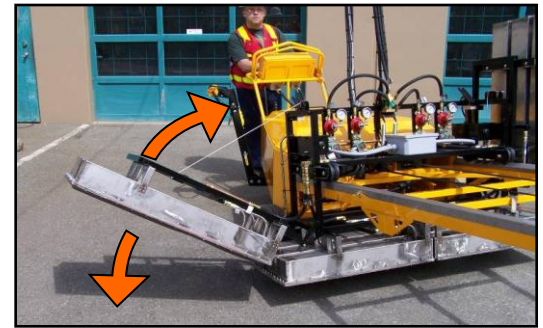

Tilt Brake - A cable actuated brake feature allows you to tilt the rails relative to the wheeled sub-frame, and hold it in that position. The brake is "normally on", that is, the lever on the handlebar must be pulled to *disengage* the brake. Simply let go of the lever for the brake to engage again. Note: the braking force is quite moderate, and set to just hold position when driving the machine.



Whenever the machine is to be moved, make sure that it is tilted "back" to avoid damaging the pilots or front legs.

CAUTION: The flames from the PILOT LIGHTS will continue to burn even when the heaters have been shut down. This could overheat a small area of asphalt if the machine is left to idle for too long in one spot. To minimize this, always leave the machine tilted "back" so the pilot flames are angled upwards.



Preparing For Work

Propane Supply – The SR-120 requires a minimum of 3 - 100 lb (45 kg) vapor withdrawal propane bottles. **ONLY operate with the bottles standing upright.**

Strap the first stage regulator assembly securely to one of the bottles and connect the remaining bottles together making sure that there are no leaks.

Attach the propane line of the 100ft (30m) long “umbilical cord” (electrical cord and propane hose).

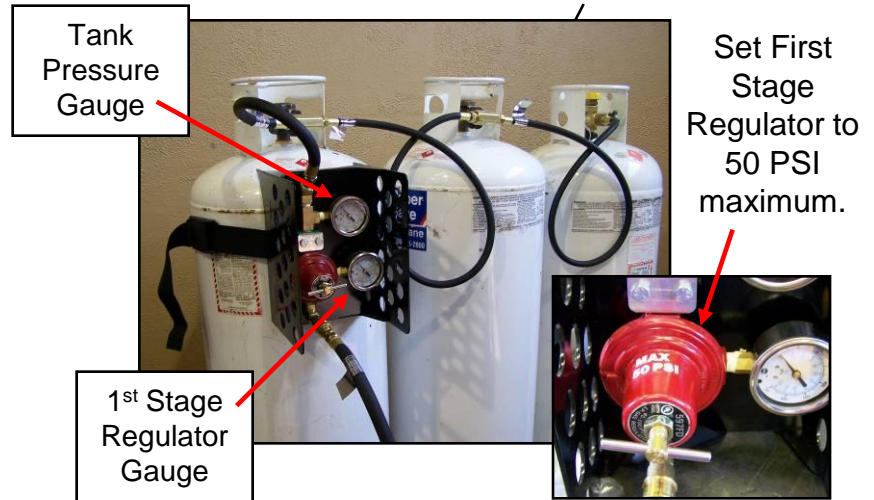

Electrical Power – Plug the power cord on the “umbilical cord” into 110 VAC power outlet. **The Honda EU3000 is the required generator.**



Connect “Umbilical Cord” – Connect the propane hose and power cord on the drive handle.



Open Main Shut-Off Valve – located on the right side of the steering arm.

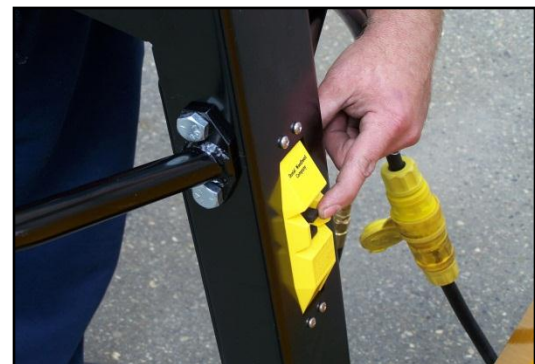

Ground Fault Interrupt (GFI) – push the top button on the GFI located on the front of the steering arm. The green light should be on.

Preparing For Work

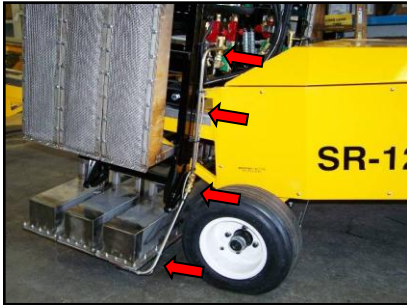

Pilot Light Location - The two pilot lights (left and right) are located on the outside of the center heater banks, just forward of the front wheels.

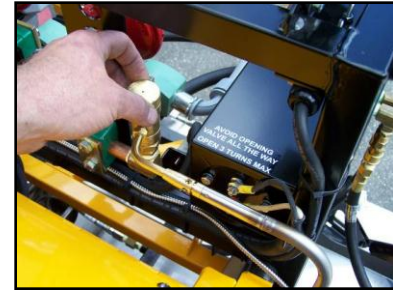

Open the Pilot Valves – open the brass pilot valve **a maximum of 3 turns** to prevent damaging the pilot valve diaphragm.



Ignite the Pilots - use a common barbecue lighter (supplied). If the main line from the propane tanks is full of air, it may take up to a minute to bleed the air off before the pilots will light.

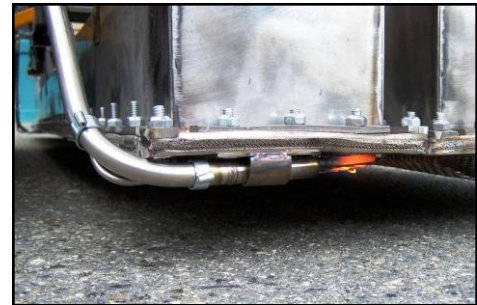

Pilots Verification - Once you can see or hear that the pilot flames are lit, the SR-120 is ready to begin heating the asphalt.

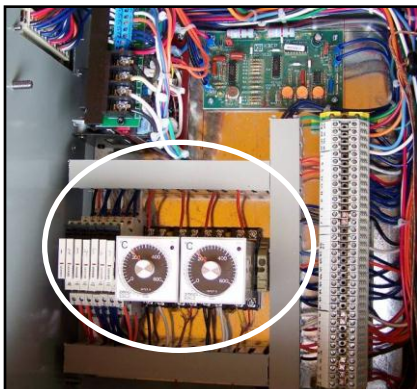

Flame Safety System – The heaters will only move if the pilot lights are burning. Safety regulations require that the pilot light temperature sensors (inside the 120 VAC electrical box under the hood) are set to at least 200°C. **NEVER OPERATE THE HEATERS WITH THESE TURNED DOWN TO ZERO.**

Note: If the red light is on, it indicates that the pilot light is not lit.

Operating Procedure

Power ON - Pull up on the red E-stop button at the top right of the main control panel. Verify you have power by checking that the cycle counter screen lights up.



Heating Cycles – One heating cycle is defined as the heater moving all the way forward and back again to “home position”.

The counter shows the preset number of cycles (lower numbers) and the remaining cycles (upper numbers). Once all the cycles have been completed, the heaters will automatically stop cycling and the propane valves will close. The pilot flames will continue to burn.

Cycles Remaining
Preset number of Cycles
Adjust Presets



Starting the Heater – Once the pilot flames have been ignited, the cycle counter has been set to the desired number of cycles the machine is positioned correctly, simply push the **green button** to start the heating process. This will open the valves to the heaters and initiate the heating sequence. When the set number of cycles is complete the machine will shut down automatically.



FOR SR-120's # 1-9.

Multi-Speed Feature - The SR-120 has a multi-speed feature to provide more aggressive heating during the first 2 cycles. By the third cycle the truck will be traveling at full speed. To bypass the slow cycles press the **YELLOW “Full Speed Override”** button (located above the cycle counter) at any time to achieve maximum speed immediately.



Operating Procedure

Short Cycle - to concentrate heating on either the front or rear ends, it is possible to manually override the automatic cycling using the appropriate short cycle button
Note: the cycle counter will not count down unless truck reaches "home position".

CAUTION: DO NOT USE THE SHORT CYCLE BUTTON TO HOLD THE HEATER AT THE "HOME POSITION" FOR MORE THAN A FEW SECONDS, OR THE PNEUMATIC TIRE COULD OVERHEAT AND BURST.

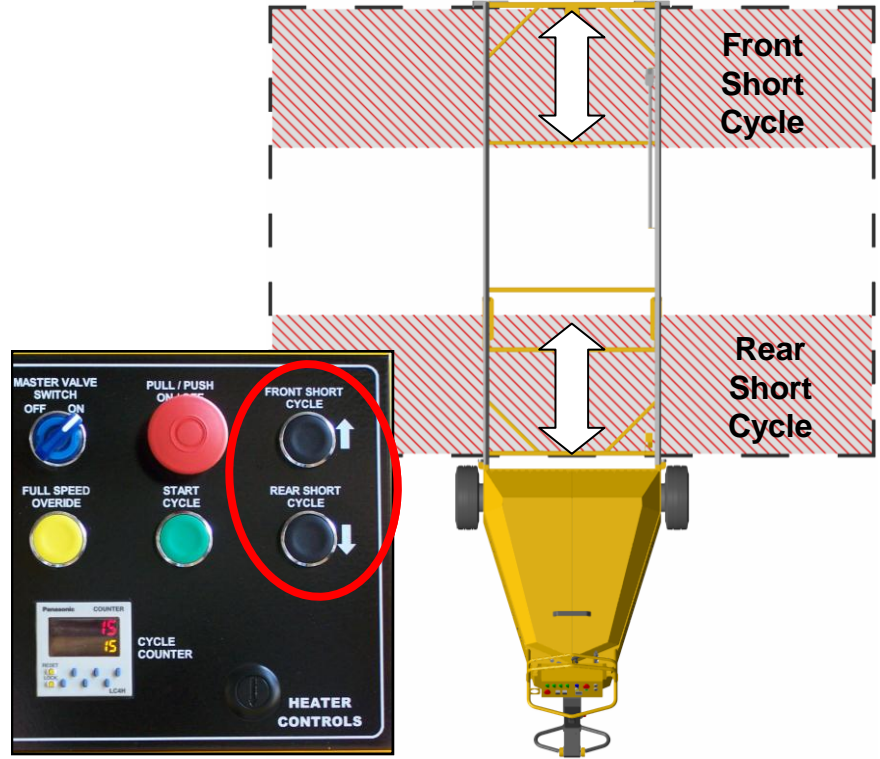

Short Heater Stroke – The front limit switch bracket is mounted to a bar so that it can be moved backward up to 3 feet to shorten the heater stroke accordingly. Simply loosen the thumb screw, slide to the desired position, and tighten the thumb screw again.

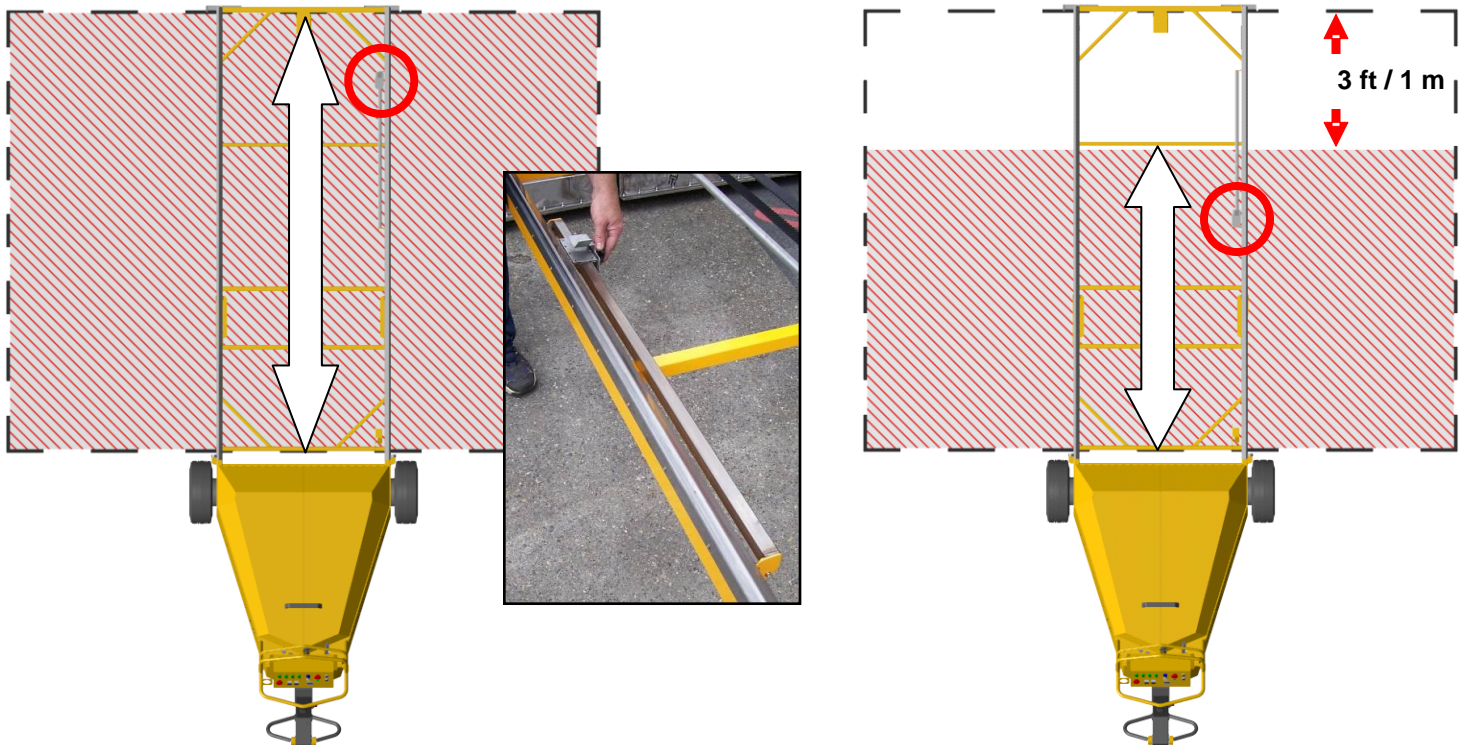

Operating Procedure

3rd Stage Regulator and Gauge
(one for each heater bank)

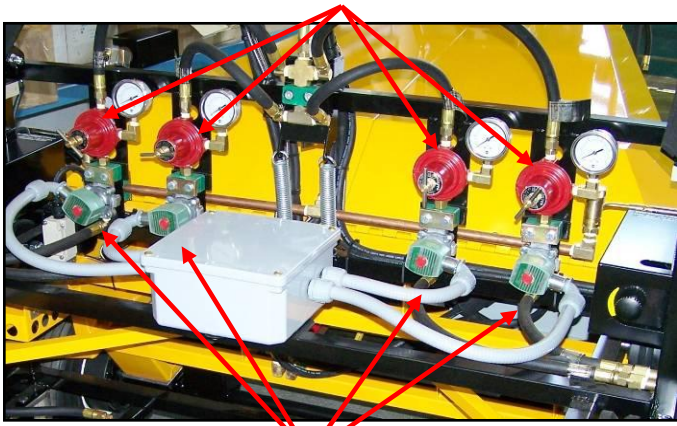

Electric Solenoid Valves
(one for each heater bank)

Heater Operating Pressure – Set each of the four 3rd stage regulators to 6-7 psi. **Too high pressure can cause “flashback” where the propane combusts inside the heater box. This significantly shortens the life of the heaters.**

In windy conditions the heaters can make a loud whistling sound. This is normal as the wind “shock cools” the outer screens causing them to shrink relative to the inner screens.

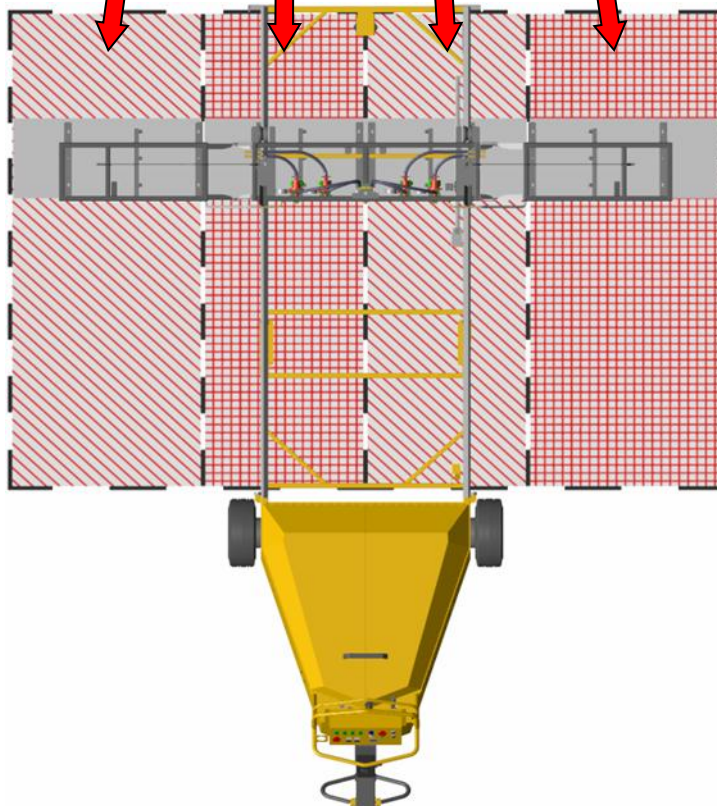

Heating Zones – The SR-120 has 4 separate “heating zones”. Each heater bank has an electric solenoid propane valve which is opened and closed with switches on the main control panel. If one zone is getting too hot, it can be switched off for a time to allow the other zones to “catch up”. On rare occasions one heater may produce a loud “popping” sound followed by a “jetting” sound and is “burning internally” (this can happen especially in windy conditions), only that one bank needs to be closed for a short time, and then opened again while the remaining banks continue to heat.

In addition, there is a “**master valve switch**” which will open or close all 4 valves at once. This is especially useful when melting DuraTherm and long “**heat soaking**” is needed. Periodically switch off the master valve switch for half a stroke, then turn it back on again, to prevent burning and ensure a good bond.

Operating Procedure

Maneuvering into Position - *Do not move the machine unless the heaters have stopped cycling and are parked in "Home Position" at the end nearest to the operator.* Make sure the machine is in the "Tilted Back" position before moving. **Never allow the heaters to pass over the propane hose.**



When the machine is positioned, it is not necessary to use the **park brake** during normal usage as the drive chain will not allow the machine to move. Use for transport and emergency only. Tilt the rail forward before heating.

Automated Heating – The heating cycle and shut-off are completely automated, once the green start button is pressed. At any time the red E-stop button (upper right of control panel) may be pressed and the cycling will stop immediately and the propane valves will close. To restart the machine pull the red E-stop button out and press the green start button. The cycles will have been reset to the preset number.



Surface Temperature – The asphalt surface temperature should be constantly monitored using an infrared thermometer to ensure correct heating is taking place. Avoid over heating the asphalt surface. Blue smoke indicates that overheating is taking place, which could affect coating bond. Do not heat the surface above 320°F (150°C).



Depth Probing – Check depth of softening of the asphalt by pushing a small screwdriver into the asphalt surface. Once the asphalt is soft to a depth of ½" (12mm) to ¾" (19mm) imprinting can take place.



Charging Batteries

Charging the Batteries –

Whenever the machine is plugged into 110 VAC power and the ground fault interrupt (GFI) is activated, the batteries will be charging. It is not necessary that either one of the E-stop buttons be pulled to “ON” position.

Whenever the machine is being used for heating, the batteries will be charging as required.

It is acceptable practice to plug the machine in overnight to ensure the batteries are topped up. However, in most cases this should not be necessary.

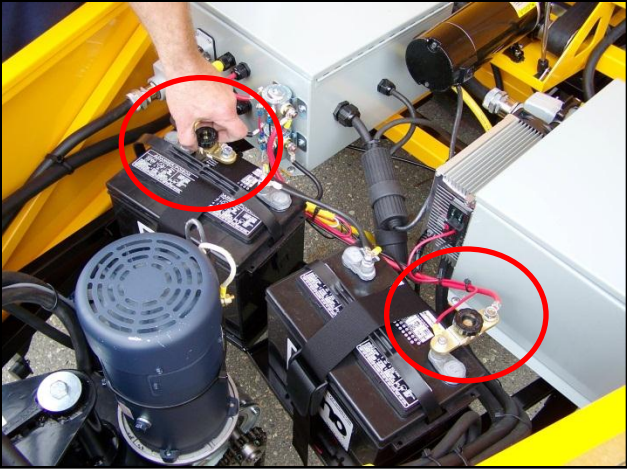
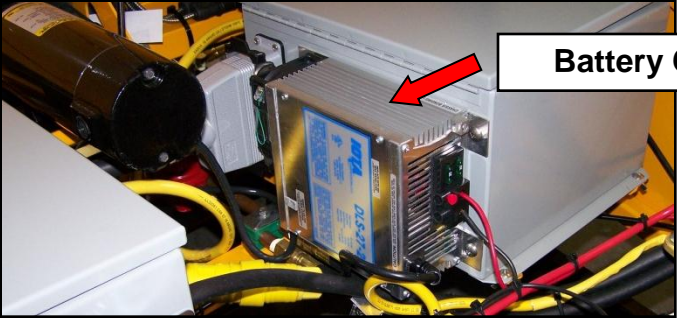
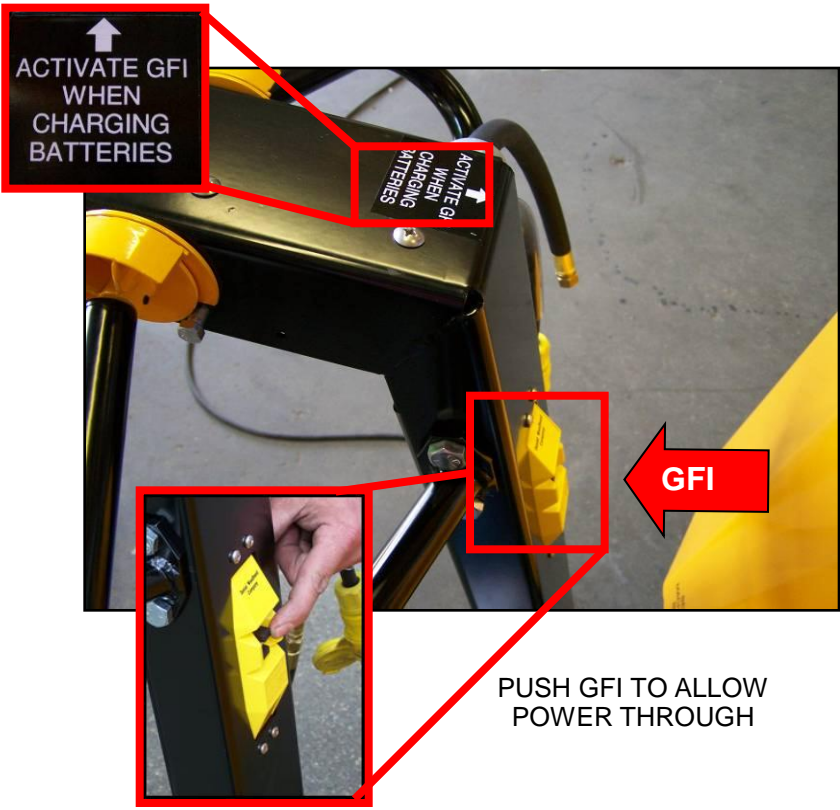

Charging and Battery Shut Off Switches – The charger is wired to bypass the battery shut off switches so charging will take place whether they are connected or not. It is good practice to leave the switches disconnected during transport and storage to prevent any power leakage.

Back Up Batteries – It is advisable to have one extra pair of deep cycle, 12 volt (marine) batteries on hand in case the power is left on and the batteries run flat. It will take about 3 hours for the batteries to be charged if they are run completely dead.

Using the Thermoplastics Bridge

The **SR-120 Thermoplastics Bridge** (sold separately) is needed to install thermoplastic products. To use the bridge, specially designed “bridge feet” need to be attached to the front legs. They are stored on the bridge, locked in place with a “quick pin”

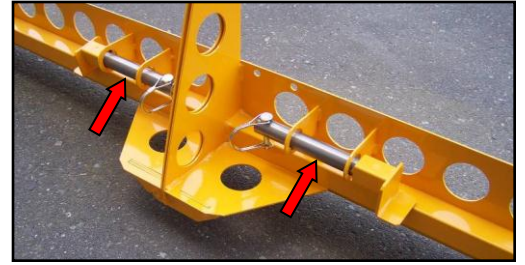

Attaching the “Bridge Feet” –

Remove the quick pin on the front foot...



...swivel the foot to the inside, and reinsert the quick pin to hold the foot up



Remove bridge foot from the bridge, slide it into the leg with the “hook” facing forward



Reinsert the quick pins to lock the foot in place. Repeat steps for the other leg as well.



Using the “Bridge Feet” – When needed, place the bridge over the melted DuraTherm and carefully lower the front feet down into the bridge channel. **CAUTION: Verify that BOTH feet are hooked onto the channel before starting the heat cycle.**

Transportation

Recommended trailer for transporting the SR-120: a landscape trailer or an enclosed auto type trailer, at least 16 feet in length, and with a rear ramp and a minimum of 6 ft high rear opening.

Loading the SR-120: VERY IMPORTANT, Always load the SR-120 onto the trailer BACKWARDS to prevent damaging the pilot lights.

Strap Rail to Handle. CAUTION: Do not pull strap too tight; Use a strap or rope, NOT a bungee

To avoid over stressing the drive wheel, prop the back end on the "U-brace" supplied with the machine

Strap the back end towards the rear. DON'T OVERTIGHTEN

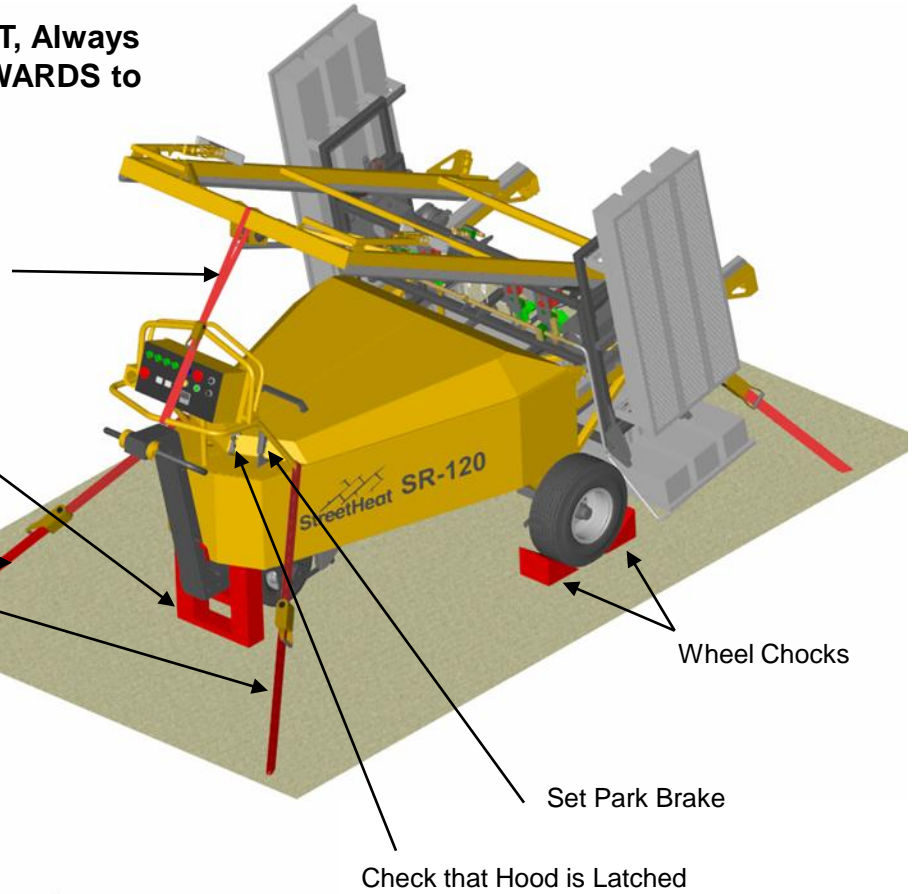

Strap the front end through tie down loops and towards the front. DON'T OVERTIGHTEN STRAP

Wheel Chocks



"Umbilical Cord" - Ensure the main gas valves on the propane bottles are shut off. Disconnect the "umbilical cord" and store in a place where they won't be damaged. **CAUTION: always detach regulator and hoses from the bottles before transporting.**

Integrated Paving Concepts Inc. is committed to providing the best possible after-market service. If you require parts or service, please visit www.ipcinstaller.com. If you have any other questions please call IPC Support at 1-800-688-5652 or +001 604 574-7510 outside North America.

